

LTM SERIES Hi-Ranger Telescopic Aerial Device

AERIAL DEVICES

Terex® Hi-Ranger Aerial Devices are known throughout the industry. They come with a long history featuring quality and innovative design.

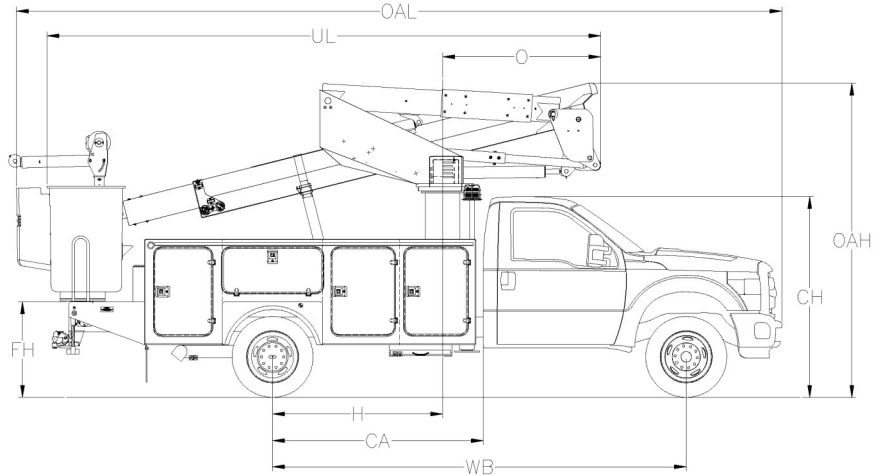

MEASUREMENTS	LTM40
	BC
Typical Frame Height (FH)	32 in. (81.3 cm)
Typical Cab Height (CH)	78 in. (198.1 cm)
Offset (O)	63 in. (160 cm)
Overall Height (OAH)	10' 4" (3.1 m)
Overall Length (OAL)	25' 4" (7.7 m)
Unit Length (UL)	19' 4" (5.9 m)
Center of Rotation (H)	68 in. (172.7 cm)
Cab to Axle (CA)	84 in. (213.4 cm)
Wheel Base (WB)	165 in. (419.0 cm)
Front Axle (FA)	7,000 lb. (3,175 kg)
Rear Axle (RA)	13,500 lb. (6,124 kg)
Gross Vehicle Weight Rating (GVWR)	19,500 lb. (8,845 kg)
Recommended Weight for Stability (With Torsion Bars)	15,000 lb. (6,803 kg)
Frame Section Modulus	9.75 in ³
Frame Yield Strength	36,000 psi
Frame RBM	360,000 in-lbs

STANDARD EQUIPMENT

- End Mounted 24 x 30 x 42" One Person Platform
- Platform Capacity of up to 400 lbs. (181 Kg)
- 4-Function Single Stick
- Safety Harness With Attached Lanyard
- Continuous Unrestricted Worm Gear Rotation
- Category "C" Rating Per ANSI A92.2
- Full Pressure Controls on Side of Platform
- Individual Lever Lower Controls
- Platform Tilt Control At Upper and Lower Controls
- Hydraulic Platform Leveling
- Steel Main Boom
- Fiberglass Second Section Boom
- Fiberglass Lift Boom Insert
- Lower Controls Above Rotation
- Full Pressure, Open-Center Hydraulic System
- 20 Gallon Hydraulic Oil Reservoir
- Engine Stop/Start
- Padded Boom Rest
- Outrigger Interlock
- Moving Outrigger Alarm
- Truck Level Indicator
- Powder-Coated Finish Paint

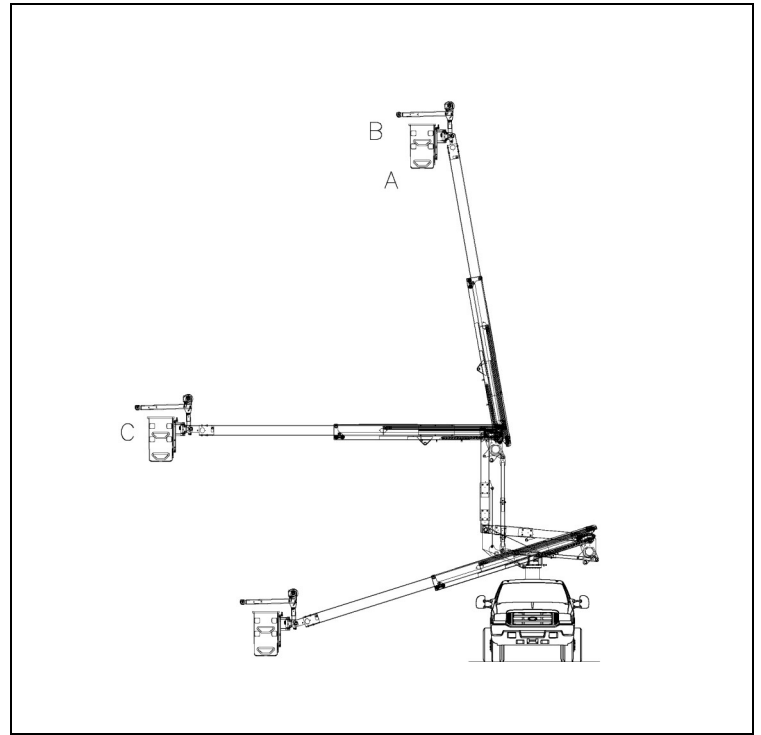

CAPACITIES AND DIMENSIONAL DATA (Based on a 40 Inch Frame Height)

	Bottom of Platform Height (A)	Working Height (B)	Horizontal Reach (C)	Boom Travel	
				Lower Boom	Upper Boom
LTM40 (Low Pro OR)	39.5 ft (12.0 m)	44.5 ft (13.6 m)	30.7 ft (9.4 m)	-5° to 90°	-20° to 80°
LTM40 (Modified A's OR)	39.5 ft (12.0 m)	44.5 ft (13.6 m)	30.0 ft (9.1 m)	-5° to 85°	-20° to 80°

OPTIONAL EQUIPMENT

- Various Side and End Mount Platforms
- Various Platform Covers
- Liners with or Without Steps
- Hydraulic Platform Rotator (180° End Mt., 90° Side Mt.)
- 24" Platform Lifter
- Jib Options
 - Various Jib Extension Systems
 - Hydraulic Articulating Jib/Winch, Side Mt 800 lbs.
- Manual or Hyd Extension / Articulation 800 lbs.
- Single Wire / 46 Kv Insulated Single Line Lifter/ Multi-Phase Attachments
- Automatic Boom Latch
- Lower Boom Lifting Eye
- Hydraulic Tool Outlets
- Auxiliary Power
- Auxiliary Let Down System
- Boom Overstow Protection
- Boom Stow Interlock
- Boom Storage Warning Light
- Outrigger Sag Light
- Various Types of Outriggers
- Truck Grounding Cable and Clamp
- HyPower™ SmartPTO by Viatic

Effective Date: June 2022. Product specifications and prices are subject to change without notice or obligation. The photographs and/or drawings in this document are for illustrative purposes only. Refer to the appropriate Operator's Manual for instructions on the proper use of this equipment. Failure to follow the appropriate Operator's Manual when using our equipment or to otherwise act irresponsibly may result in serious injury or death. The only warranty applicable to our equipment is the standard written warranty applicable to the particular product and sale and Terex makes no other warranty, express or implied. Products and services listed may be trademarks, service marks or trade-names of Terex Corporation and/or its subsidiaries in the USA and other countries. All rights are reserved. Terex® is a registered trademark of Terex Corporation in the USA and many other countries. Copyright 2022 Terex Corporation.